

Capacity (L) of double-wall tank	I.D. (mm) of double-wall tank	Cylinder height (mm) of double-wall tank	Overall height (mm) of double-wall tank	Roof height (mm) of double-wall tank
60,000	3,400	6,810	7,270	460
60,000	3,600	6,050	6,530	480
60,000	4,000	4,850	5,390	540
70,000	3,400	7,970	8,430	460
70,000	3,600	7,080	7,560	480
70,000	4,000	5,690	6,230	540
80,000	3,400	9,130	9,590	460
80,000	3,600	8,120	8,600	480
80,000	4,000	6,525	7,065	540
90,000	3,400	10,290	10,750	460
90,000	3,600	9,150	9,630	480
90,000	4,000	7,360	7,900	540
100,000	3,400	11,450	11,910	460
100,000	3,600	10,190	10,670	480
100,000	4,000	8,200	8,740	540
110,000	3,600	11,220	11,700	480
110,000	4,000	9,040	9,580	540
120,000	3,600	12,260	12,740	480
120,000	4,000	9,880	10,420	540
130,000	3,600	13,290	13,770	480
130,000	4,000	10,710	11,250	540
140,000	3,600	14,320	14,800	480
140,000	4,000	11,550	12,090	540
150,000	3,600	15,360	15,840	480
150,000	4,000	12,390	12,930	540
160,000	3,600	16,390	16,870	480
160,000	4,000	13,230	13,770	540
170,000	3,600	17,430	17,910	480
170,000	4,000	14,070	14,610	540
180,000	3,600	18,460	18,940	480
180,000	4,000	14,900	15,440	540
190,000	3,600	19,490	19,970	480
190,000	4,000	15,740	16,280	540
200,000	3,600	20,530	21,010	480
200,000	4,000	16,580	17,120	540

Custom sizes and designs are available on request.

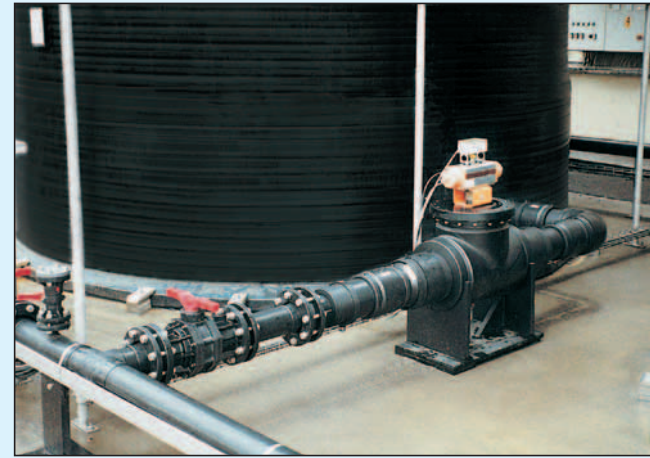

Automatic Extrusion Welding Machine. Bottoms can be welded to the shells



DN 100 PN 10 double-pipe take-off line with manually operated double-pipe PVC/EPDM ball valve, PE/PE inner/outer piping and leakage monitor system.



2 double-wall HDPE storage tanks, diameter 4000 mm, overall height 17,120 mm, capacity 200,000 L



formoplast
Plastic Tanks and Vessels

formoplast HDPE tanks are certified to demanding standards by the German Institute of Construction Technology of Berlin.
Certification No. Z-40.21-169

With WHG 19I Environmental Certification

With products from formoplast, you can be assured of compliance with environmental regulations

formoplast
Kunststofftechnik GmbH

Dieselstraße 19
D-89160 Dornstadt
Tel.+49 (0)73 48-98 69-0
Fax+49 (0)73 48-98 69-40
info@formoplast.com
www.formoplast.com

Third-party inspection by



FREE STANDING DOUBLE-WALL HDPE STORAGE TANKS

Helically Wound with **VSM**
Vacuum **S**afety **M**onitoring

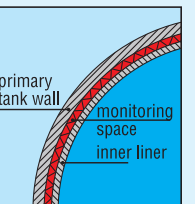

HIGHEST SAFETY AND DECISIVE ADVANTAGES WITH HDPE TECHNOLOGY

Certified For Use In Groundwater Protection According To WHG 19 I

- Outstanding chemical resistance
- Excellent corrosion and weathering resistance
- Homogeneous monolithic material
- Good insulation properties
- Low space requirements
- Easy to transport and install
- Lightweight
- Low thermal conductivity
- Long service life
- Simple, cost-efficient retrofitting of accessories
- Practically maintenance-free



formoplast double-wall polyolefin (HDPE, PE 100 or PP) tanks are the safe and environment-friendly solution for storage of hazardous liquids.

Their double wall design with integrated VSM leak detection eliminates the need for costly secondary containment systems. The annular void space between the walls is monitored by an officially certified leak detection device. The pressure in the void space is maintained within narrow limits by a vacuum pump. An increase in pressure above the upper limit is an indication of a leak which immediately triggers a visual and acoustic alarm. The alarm can be turned off only by resetting a sealed switch.

Available Dimensions:

Capacities: 1000 to 200,000 litres

Diameters: 800 to 4000 mm

formoplast double-wall tanks comply with all regulations:

- Certified for use in construction
- Certified for use in industrial operations
- Certified for use in groundwater protection
- Customer-specific approvals / inspections
- Third-party inspection by TÜV Süd



5 double-wall HDPE storage tanks, each with 100 cbm capacity, 3600 mm in diameter, 10.500 mm high; equipped with access ladders, peripheral safety railings and interconnecting walkway bridges.

Double-Wall HDPE Spiral-Wound Flat-Bottom Tanks

Capacity (L) of double-wall tank	I.D. (mm) of double-wall tank	Cylinder height (mm) of double-wall tank	Overall height (mm) of double-wall tank	Roof height (mm) of double-wall tank
500	800	1,030	1,140	110
1,000	1,000	1,315	1,445	130
1,500	1,000	1,985	2,115	130
1,500	1,200	1,380	1,540	160
2,000	1,200	1,840	2,000	160
2,000	1,500	1,180	1,380	200
2,500	1,200	2,300	2,460	160
2,500	1,500	1,475	1,675	200
3,000	1,500	1,765	1,965	200
3,000	1,900	1,060	1,310	250
3,500	1,500	2,055	2,255	200
3,500	1,900	1,260	1,510	250
4,000	1,500	2,355	2,555	200
4,000	1,900	1,485	1,735	250
5,000	1,500	2,950	3,150	200
5,000	1,900	1,835	2,085	250
5,000	2,000	1,650	1,920	270
6,000	1,500	3,545	3,745	200
6,000	1,900	2,205	2,455	250
6,000	2,000	1,980	2,250	270
7,000	1,900	2,575	2,825	250
7,000	2,000	2,315	2,585	270
7,000	2,250	1,780	2,080	300
8,000	1,900	2,945	3,195	250
8,000	2,000	2,650	2,920	270
8,000	2,250	2,020	2,320	300
9,000	1,900	3,320	3,570	250
9,000	2,000	2,990	3,260	270
9,000	2,250	2,300	2,600	300
9,000	2,500	1,910	2,240	330
10,000	2,000	3,320	3,590	270
10,000	2,250	2,550	2,850	300
10,000	2,500	2,120	2,450	330
10,000	2,800	1,680	2,060	380
12,000	2,000	3,990	4,260	270
12,000	2,250	3,090	3,390	300
12,000	2,500	2,550	2,880	330
12,000	2,800	2,020	2,400	380

Double-wall storage tank, equipped with cage ladder and safety bar, access platform for top manhole.

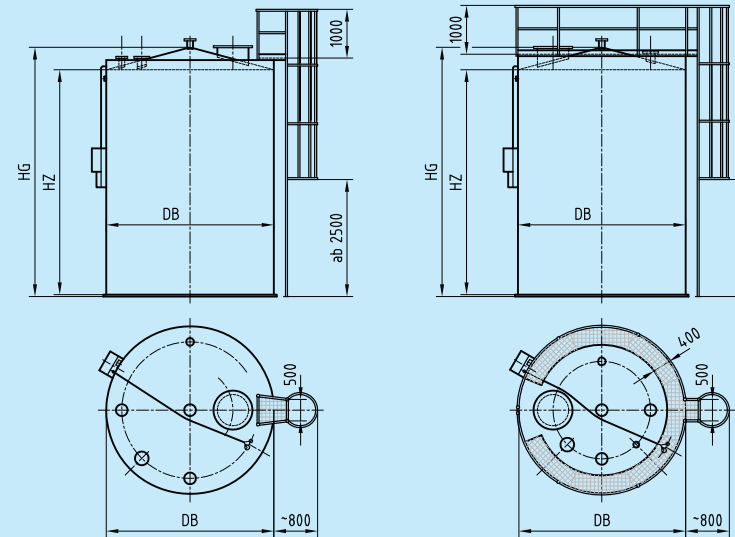

Double-wall storage tank, equipped with cage ladder and safety bar, peripheral safety railing with gratings.

Double-Wall HDPE Spiral-Wound Flat-Bottom Tanks

Capacity (L) of double-wall tank	I.D. (mm) of double-wall tank	Cylinder height (mm) of double-wall tank	Overall height (mm) of double-wall tank	Roof height (mm) of double-wall tank
15,000	2,250	3,880	4,180	300
15,000	2,500	3,190	3,520	330
15,000	2,800	2,530	2,910	380
15,000	3,000	2,210	2,610	400
20,000	2,250	5,200	5,500	300
20,000	2,500	4,250	4,580	330
20,000	2,800	3,370	3,750	380
20,000	3,000	2,950	3,350	400
20,000	3,400	2,285	2,745	460
20,000	3,600	2,040	2,520	480
25,000	2,250	6,540	6,840	300
25,000	2,500	5,340	5,670	330
25,000	2,800	4,240	4,620	380
25,000	3,000	3,700	4,100	400
25,000	3,400	2,865	3,325	460
25,000	3,600	2,560	3,040	480
30,000	2,250	7,850	8,150	300
30,000	2,500	6,410	6,740	330
30,000	2,800	5,090	5,470	380
30,000	3,000	4,440	4,840	400
30,000	3,400	3,340	3,800	460
30,000	3,600	3,075	3,555	480
35,000	2,800	5,950	6,330	380
35,000	3,000	5,185	5,585	400
35,000	3,400	4,025	4,485	460
35,000	3,600	3,592	4,072	480
40,000	2,800	6,805	7,185	380
40,000	3,000	5,930	6,330	400
40,000	3,400	4,490	4,950	460
40,000	3,600	4,110	4,590	480
50,000	2,800	8,430	8,810	380
50,000	3,000	7,420	7,820	400
50,000	3400	5,800	6,225	460
50,000	3,600	5,140	5,620	480

Custom sizes and designs are available on request.

